

WEARABLE SCANNERS

Wearable Scanner Productivity at Long Range

Announcing a scanner that breaks the distance barrier in wearable scanning. Introducing the WS 1200-LR, Symbol's new long-range, wearable bar code scanner.

Cabled to Symbol's wearable computer, the WS 1200-LR is worn on the back of the hand and triggered by a low profile, thumb-activated switch that fits securely on an index finger. Because the fingers are left free, the scanner is exceptionally well suited for package-handling-intensive activities such as order picking, stock pulling, and put-away.

Built Tough for Tough Environments

The WS 1200-LR is ruggedly built to withstand demanding industrial environments such as those found in warehouses, transportation and logistics operations, distribution centers, and manufacturing sites. The housing is rigid and durable, and well protected from abrasion by a removable/replaceable plastic cap. A jacket made of a flexible, energy-absorbent elastomer material prevents damage to the scan engine if it is dropped, or repeatedly knocked against shelving. Moreover, the unit is very effectively sealed against internal contamination from dust and moisture.

And the scanner is easy to use. Just aim it at a bar code and press the switch. An innovative "aim spot" is used to guide the scan beam, making long-range scanning quick and accurate. The scan engine in the WS 1200-LR is Symbol's field-proven SE 1200-LR, which delivers exceptional long-range scanning performance in an impressively small package. For example, the WS 1200-LR can read a 55-mil bar code from as far away as 8 ft./2.4 m and a 15-mil bar code from as close as 7 in./17.8 cm. This outstanding scanning capability makes it ideal in industrial applications where bar codes have to be scanned from distances longer than an arm's length.

Advanced Ergonomics in a Durable Package

This wearable scanner is comfortable and practical, and is designed for right- or left-handed use. Positioned out of the way on the back of the hand, the weight of the scanner, 3.5 oz./98 gm, is evenly distributed, ensuring that it can be worn indefinitely without fatigue. The adjustable attachment glove that secures the WS 1200-LR scanner to the back of the hand fits hands of all sizes and is completely washable. Glove, straps, trigger and the scanner's rubber cap – the parts that get the most wear – are replaceable at minimal cost. Finally, for user safety, the cable linking the scanner to the trigger breaks away easily to avoid injury to the finger.



Features	Benefits
Long-range scanning performance	Easily captures bar code data on labels that are out of reach
Innovative aim spot	Helps to position the scan beam making long-range bar code scanning fast and accurate
Rugged design	Stands up to tough industrial environments
Replaceable trigger, glove and rubber cap	Replaceable high-wear components extend the life of your investment
Washable attachment glove	Each user maintains personal attachment glove for hygiene
Breakaway force of 4 lbs./8 kg on all cables	To protect employees, scanner automatically breaks away from the hand
Ergonomic design	Back-of-the-hand scanning leaves the operator's hands free to move packages, products or materials, improving efficiency and productivity
Low power consumption maximizes battery life	Maintains operators' productivity as battery provides power for a full work shift on one charge when worn with the wearable wrist computer

System Adapts to the Task

The WS 1200-LR is cabled to a Symbol wearable wrist computer. Together they form a complete productivity system with today's most advanced ergonomics, robust data collection capabilities, and batch processing or wireless communications using Symbol's Spectrum24® wireless technology. The computers in the WSS system weigh just 11.3 oz./316 gm for comfortable wear over extended periods and a long-lasting 1350 mAh lithium ion battery delivers power over a full shift and can be recharged in just over two hours.

Symbol systems are critical to business success in data-intensive, time-critical environments because our systems help you capture, access and manage information at the point of activity. To find out how the WS 1200-LR can improve your productivity, contact any of our convenient locations on the back address panel, or visit us at www.symbol.com

WS 1200-LR Specification Highlights

Physical Characteristics

Voltage:	5 volts \pm 10%
Current:	115 mA typical
Standby Current:	50 μ A
Weight:	3.5 oz./98 gm
Color:	Gray
Dimensions (without cables attached):	2.7 in. x 2.4 in. x 1.5 in./6.8 cm x 6.1 cm x 3.8 cm

Performance Characteristics

Light Source:	Visible laser diode operating at 650 nm
Scan Rate:	35 \pm 5 scans per second
Scan Angle:	23° nominal
Minimum Print Contrast:	40% absolute dark/light reflectance at 650 nm

User Environment

Ambient Light:	Sunlight: 8,000 ft.-candles/86,112 lux; incandescent, fluorescent, sodium vapor and mercury vapor: 450 ft.-candles/4,844 lux
Operating Temperature:	-22° to 122°F/-30° to 50°C
Storage Temperature:	-40° to 140°F/-40° to 60°C
Humidity:	5% to 95% (noncondensing)
Environmental Sealing:	Water: light rain or drip; Dust: small particle (.88 gm/m)
Durability:	6 ft./1.8 m drop to concrete

Regulatory

Laser Class:	CDRH Class 2, IEC 825-1 Class 2
Electrical:	Certified to UL1950, CSA C22.2 No 950 and EN60950

WS 1200-LR Decode Zone

Note: Typical performance at 68°F (20°C) on high-quality symbols

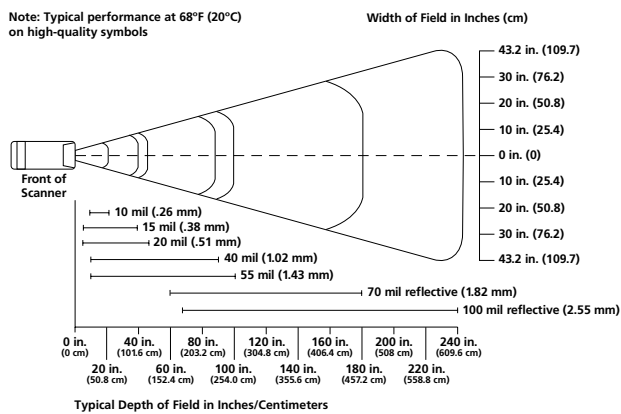

Cabled to a Symbol wrist computer, the WS 1200-LR becomes a complete productivity system.



Specifications are subject to change without notice. Spectrum24 is a registered trademark of Symbol Technologies, Inc.

For system, product or services availability and specific information within your country, please contact your local Symbol Technologies office or Business Partner.



Corporate Headquarters
Symbol Technologies, Inc.
 One Symbol Plaza, Holtsville, NY 11742-1300
 TEL: 1-800-722-6234/1-631-738-2400
 FAX: 1-631-738-5990

For Asia Pacific Area
Symbol Technologies Asia, Inc.
 (Singapore Branch)
 Asia Pacific Division
 230 Victoria Street #04-05
 Bugis Junction Office Tower
 Singapore 188024
 TEL: 65-337-6588
 FAX: 65-337-6488

For Europe, Middle East and Africa
Symbol Technologies
 EMEA Division
 Symbol Place, Winnersh Triangle
 Berkshire, England RG41 5TP
 TEL: 44-118-9457000
 FAX: 44-118-9457500

For North America, Latin America and Canada
Symbol Technologies
 The Americas
 One Symbol Plaza
 Holtsville, NY 11742-1300
 TEL: 1-800-722-6234/1-631-738-2400
 FAX: 1-631-738-5990

Symbol World Wide Web Internet Site
 For a complete list of Symbol subsidiaries and Business Partners worldwide contact us at:
<http://www.symbol.com>
 E-mail: webmaster@symbol.com



Part No. HH Printed in USA 8/00 ©2000 Symbol Technologies, Inc.
 Symbol is an ISO 9001 and ISO 9002 UKAS, RVC, and RAB Registered company, as scope definitions apply.





BARCODING, WIRELESS AND DATA COLLECTION

Our customers turn to us to help them become more productive and profitable. TPI's expertise guarantees your project will be successful: on time, on budget and meet your ROI requirements.

TPI will facilitate your entire wireless and data collection project:

- ✓ *Business analysis*
- ✓ *Project justification & ROI*
- ✓ *Wireless design, RF site survey and spectrum analysis*
- ✓ *WWAN, WLAN design & installation*
- ✓ *Custom software*
- ✓ *Integration w/legacy systems*
- ✓ *Mobile computers*
- ✓ *Data collection terminals*
- ✓ *Barcode printers, labels and scanners*
- ✓ *RFID solutions*
- ✓ *Configuration and deployment*
- ✓ *Training and installation*
- ✓ *Service and upgrades*
- ✓ *Remote device management and support*

TPI can share best practices in data collection from a number of industries including wholesale distribution, manufacturing, healthcare and retail/consumer goods. Our expertise allows you to shorten your learning curve and increase your return on investment.

Product specification sheet provided by TPI

www.tpi1.com
888-488-4244

